

ASSEMBLY INSTRUCTION

4PCS LAVAL SET

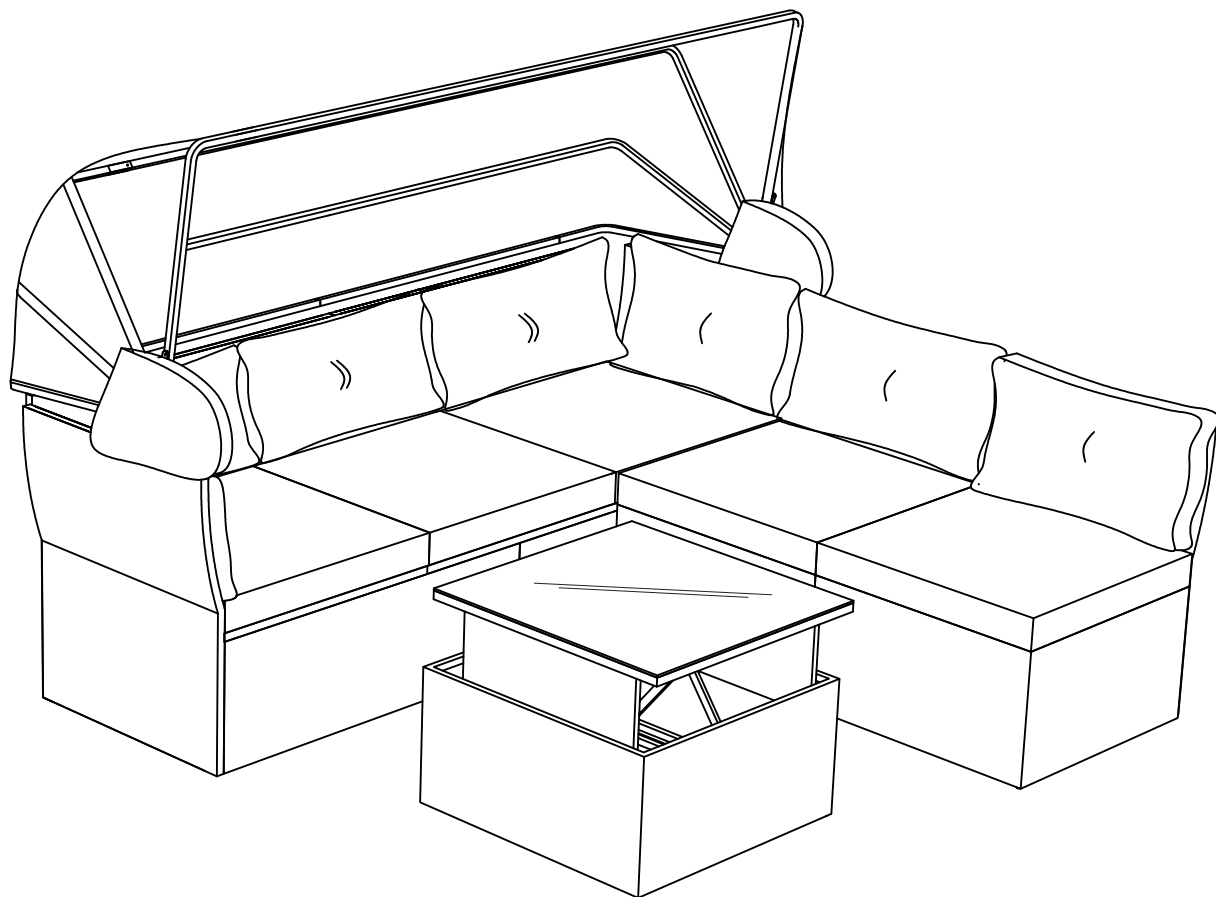

COMPONENTS:

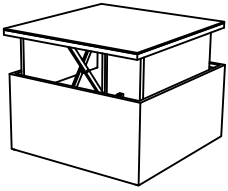

(A) x1

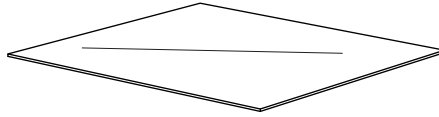

(B) x1

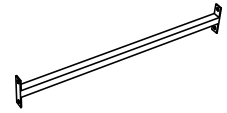

(C) x1

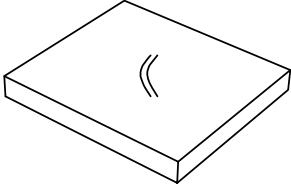

(D) x1

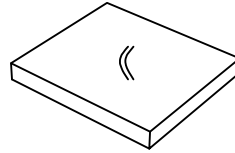

(E) x5

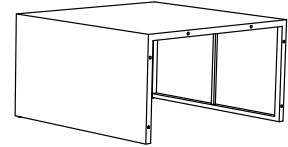

(F) x2

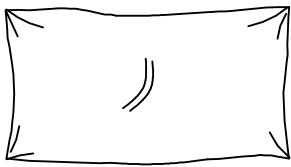

(G) x5

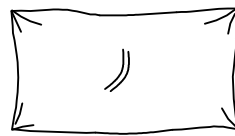

(H) x2

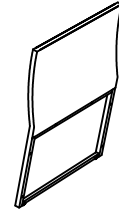

(J) x2

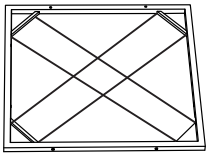

(K) x1

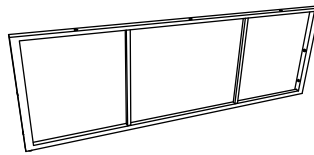

(L) x1

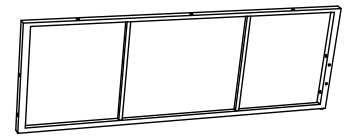

(M) x1

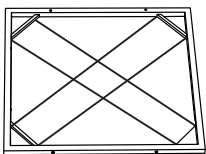

(N) x2

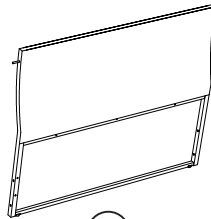

(O) x1

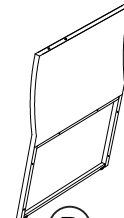

(P) x1

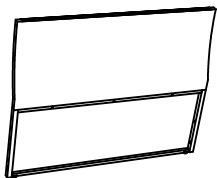

(Q) x1

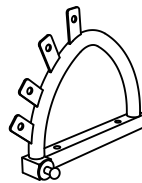

(R) x1

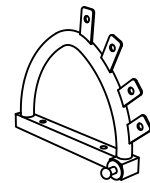

(S) x1

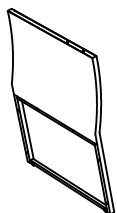

(T) x1

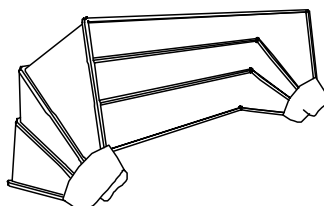

(U) x1

COMPONENTS:

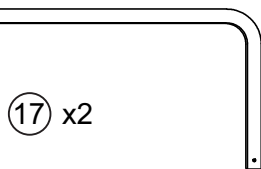
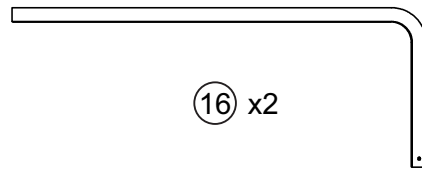
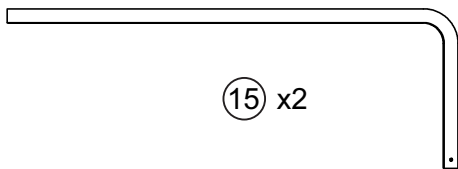
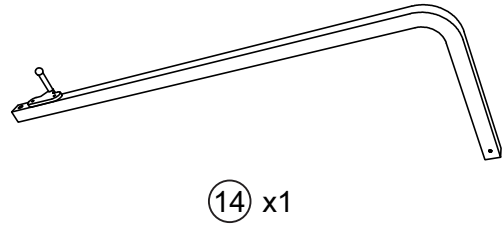
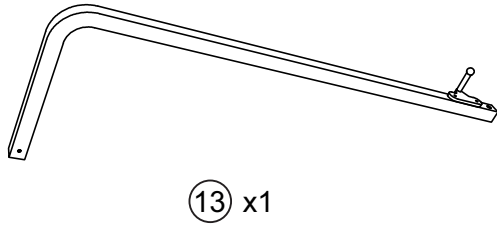
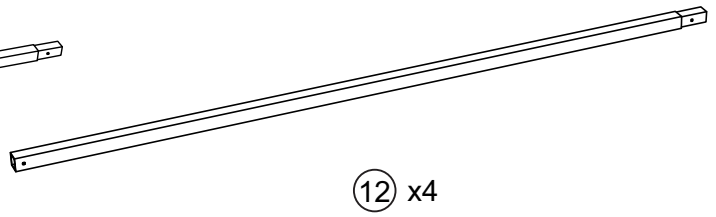

HARDWARE:

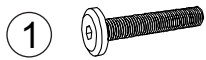

Bolt M6x40mm = 38 pcs



Bolt M6x30mm = 10 pcs



Screw = 12 pcs



Washer = 60 pcs

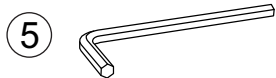

Allenkey = 2 pc



Bolt M6x20mm = 12 pcs

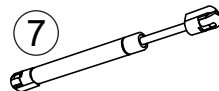

Gas Spring 160N = 2 pcs

X1

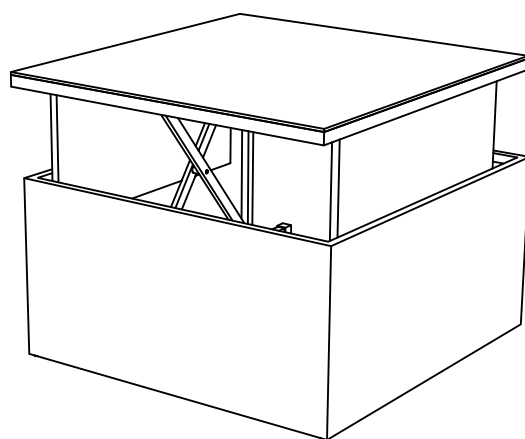

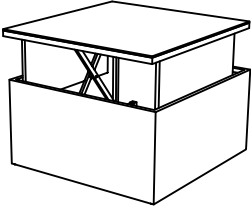
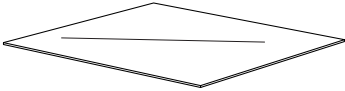
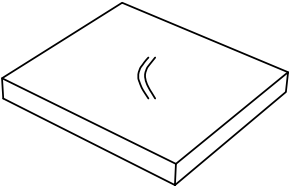
A		1 PC
B		1 PC
D		1 PC

Step 1.1: **OPTION: GLASS**

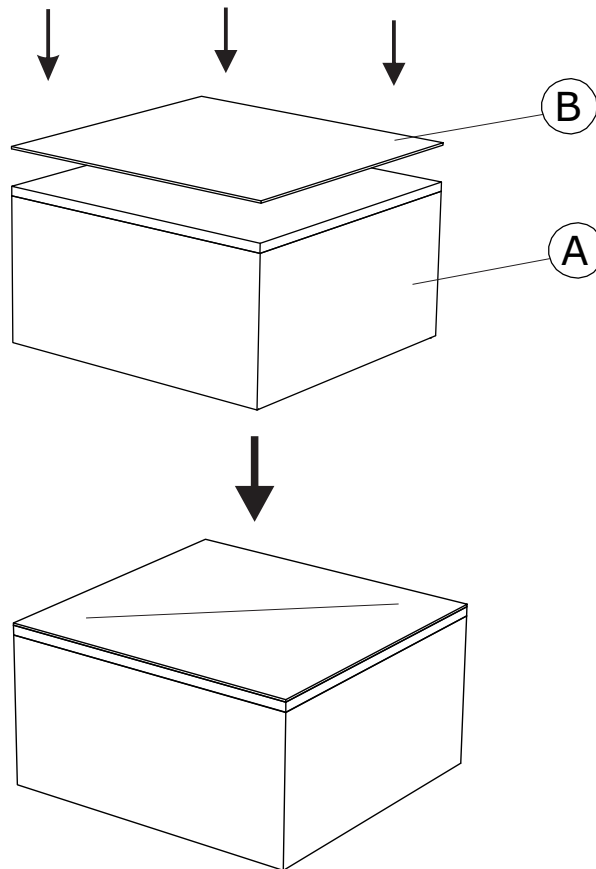

Step 1.2: **OPTION: SEAT CUSHION**

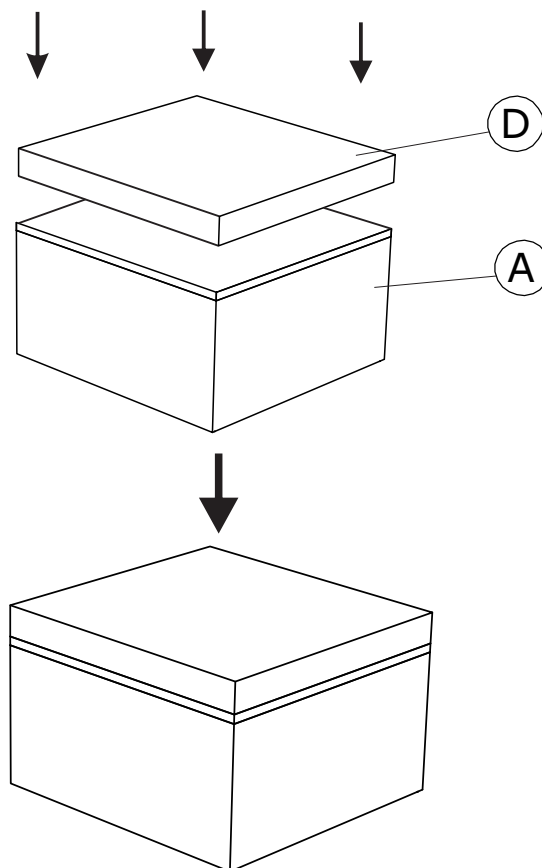

Step 2: **Pull up the table top and steel bars**

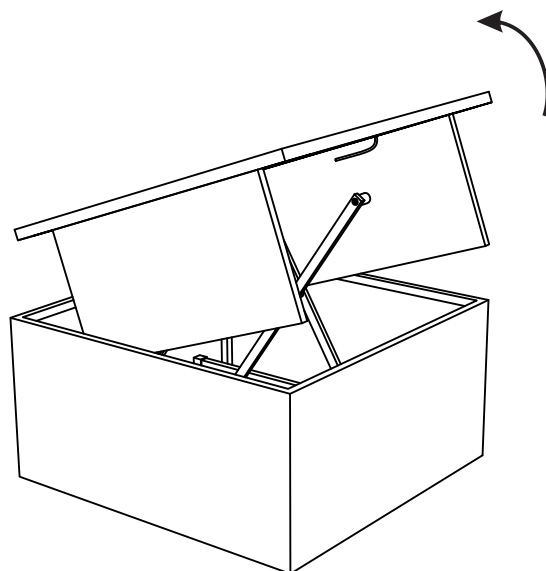

Step 3: **Put the Plastic Wheel into the position**

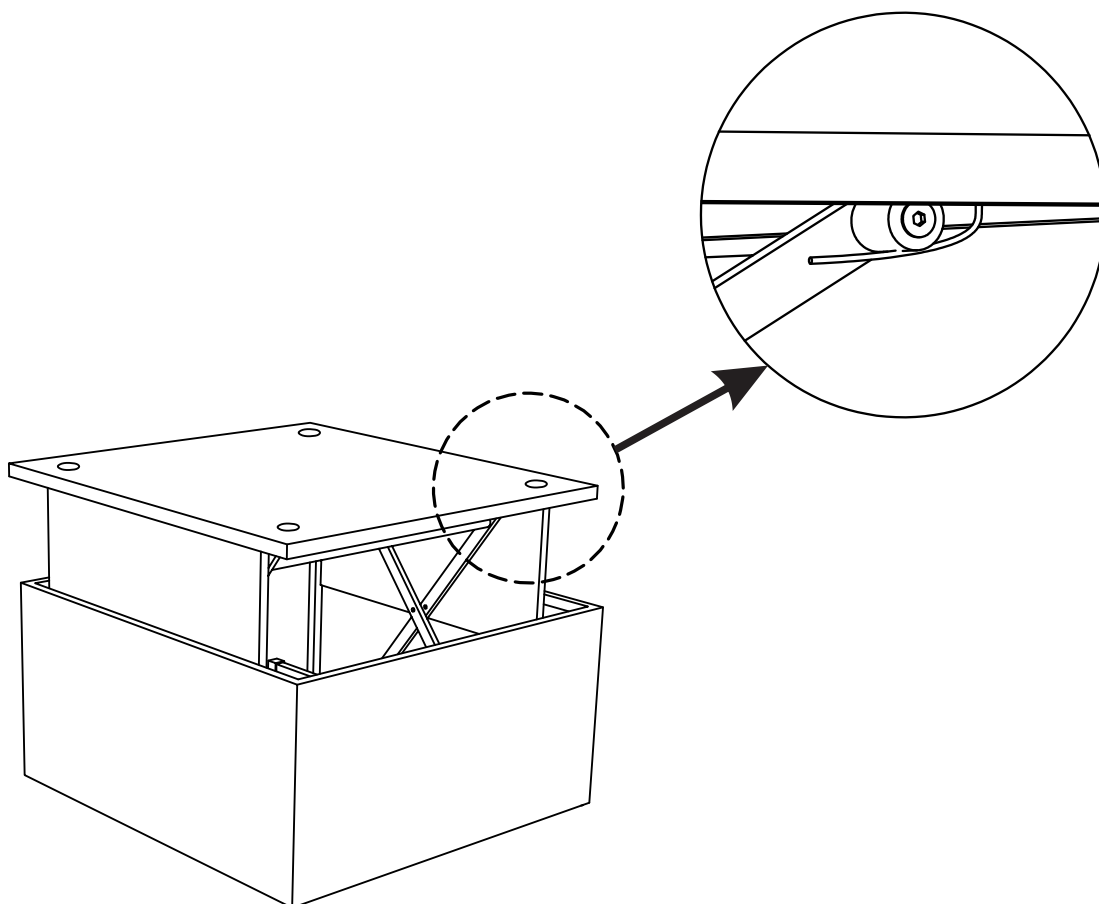

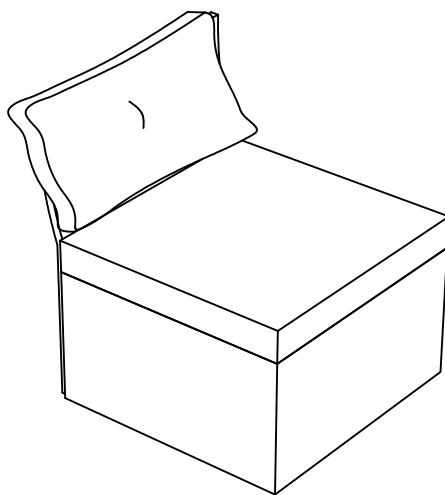

Finish

X2

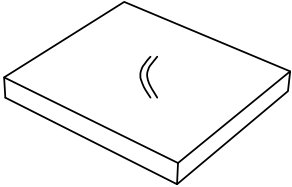
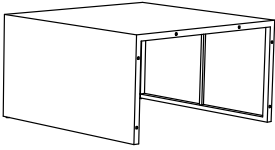
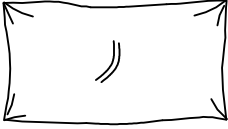
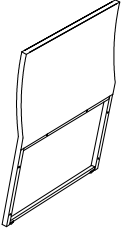

E		1 PC
F		1 PC
G		1 PC
J		1 PC

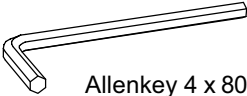
1	 M6x40 mm	6 PCS
4	 Ø6 x 14 mm	6 PCS
5	 Allenkey 4 x 80	1 PC

Step 1:

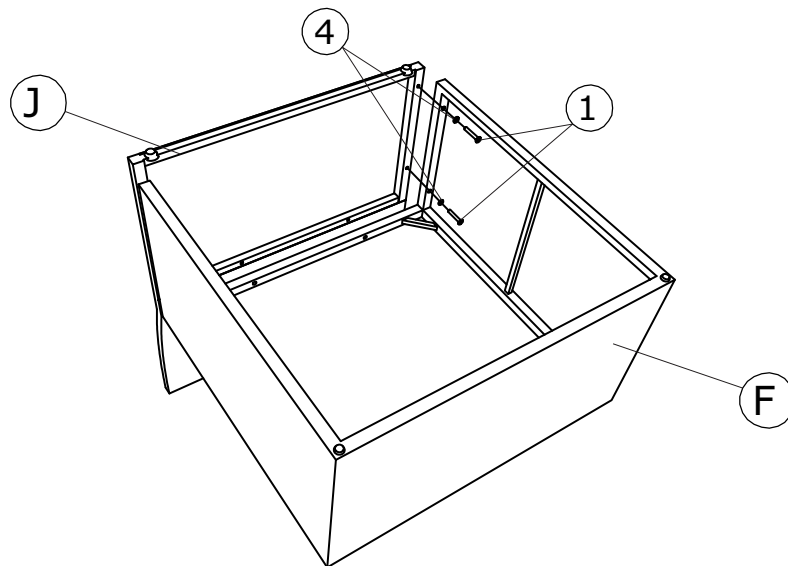

Step 2 :

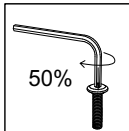
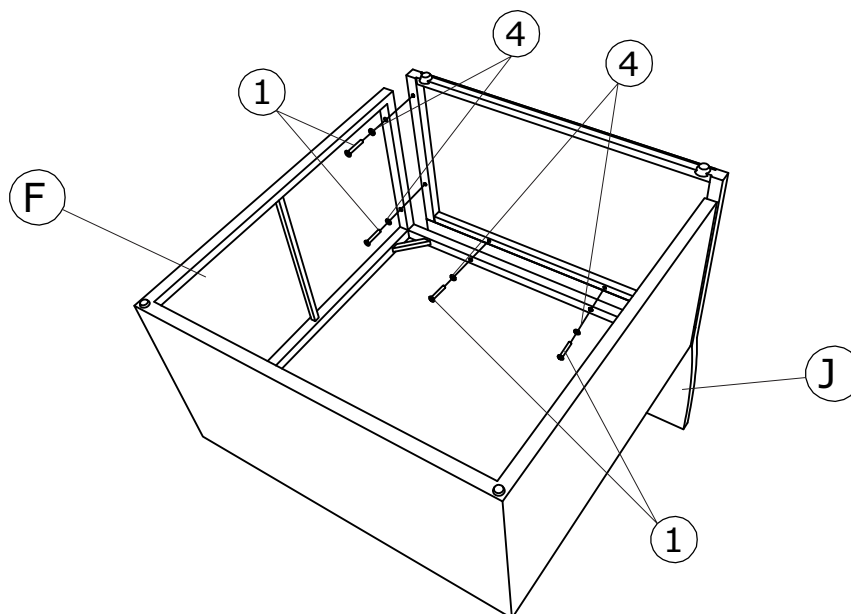



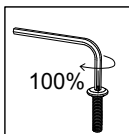
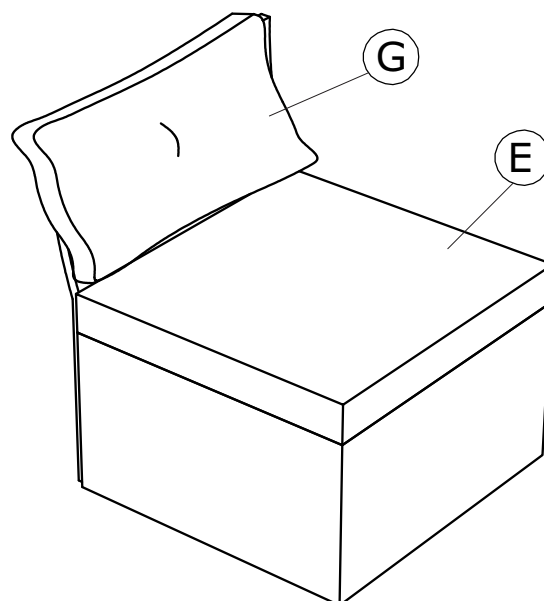

Step 3 :



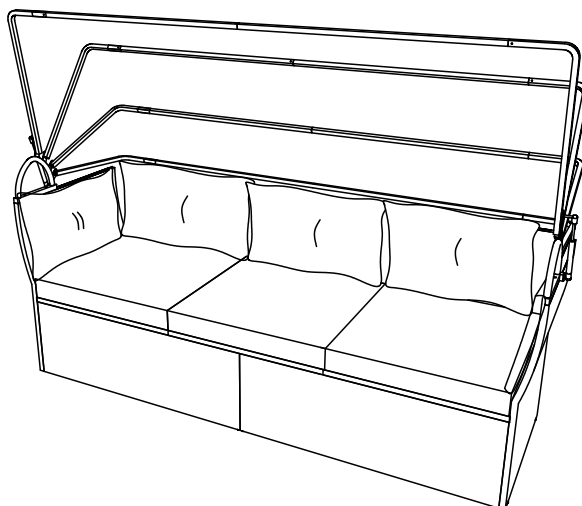



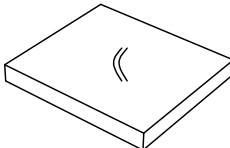

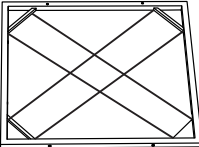
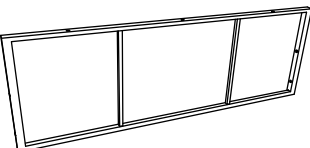
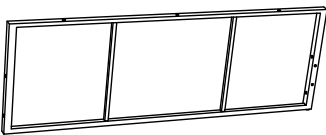
Finish





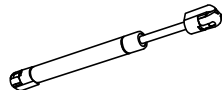

X1

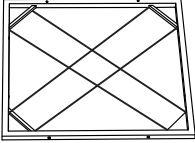
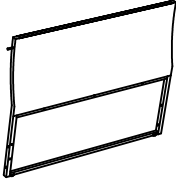
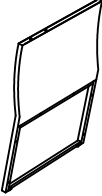
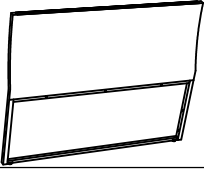
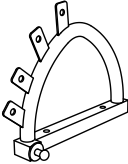
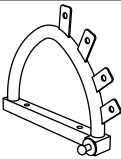
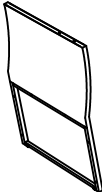
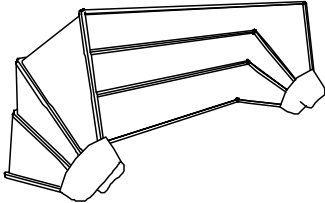

C		1 PC
E		3 PCS
G		3 PCS
H		2 PCS
K		1 PC
L		1 PC
M		1 PC

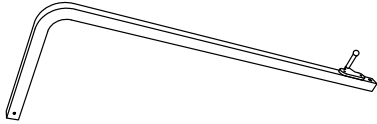
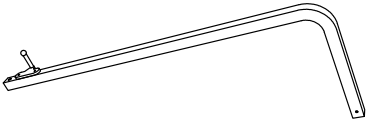
1	 M6x40 mm	26 PCS
2	 M6x30 mm	10 PCS
3		12 PCS
4		48 PCS
5		1 PC
6	 M6x20 mm	12 PCS
7		2 PCS

N		2 PCS
O		1 PC
P		1 PC
Q		1 PC
R		1 PC
S		1 PC
T		1 PC
U		1 PC

11		4 PCS
12		4 PCS
13		1 PC
14		1 PC
15		2 PCS
16		2 PCS
17		2 PCS

Step 1:

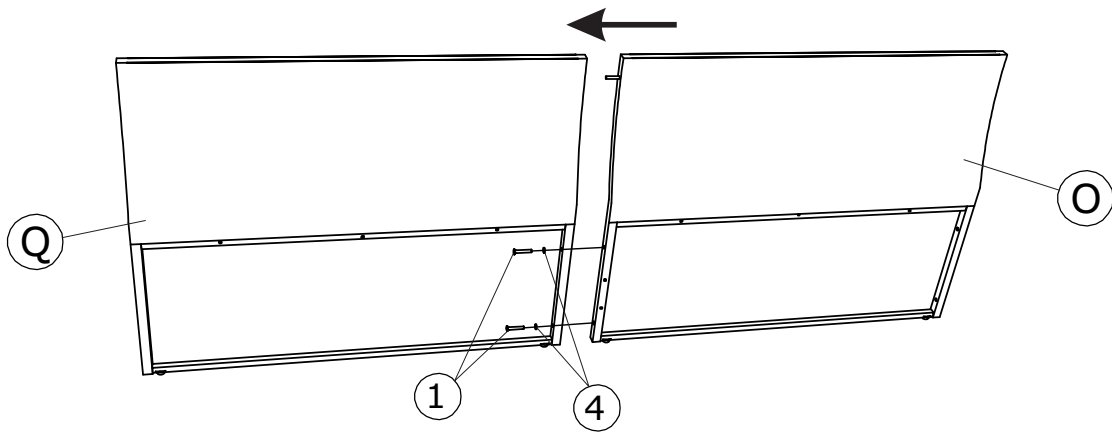

Step 2 :

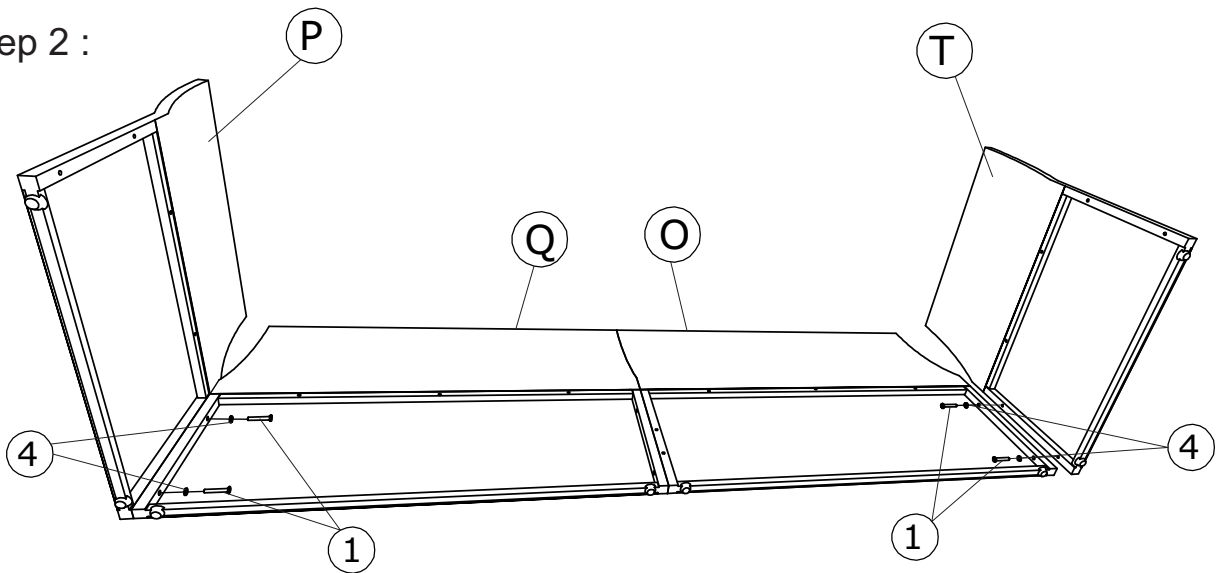

Step 3 :

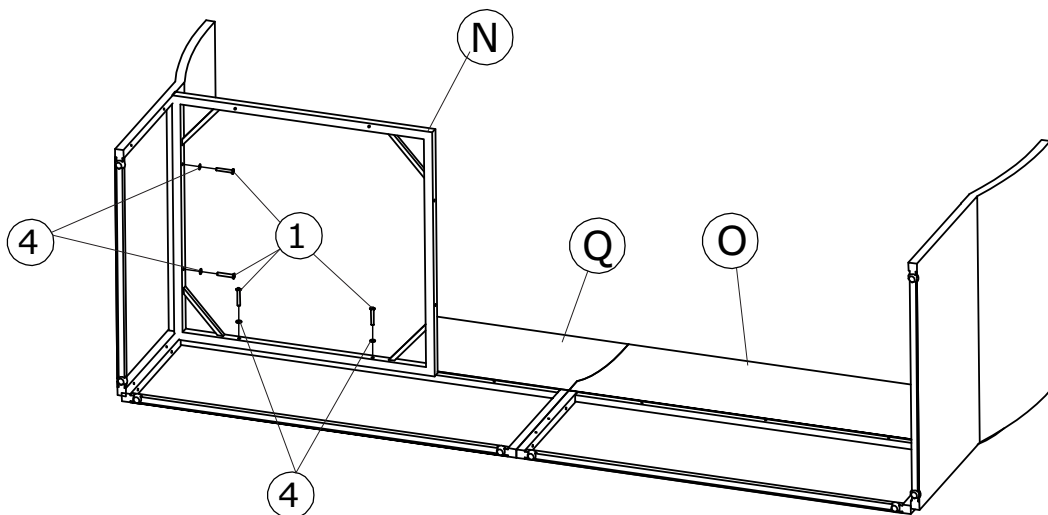
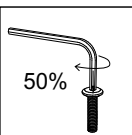

Step 4:

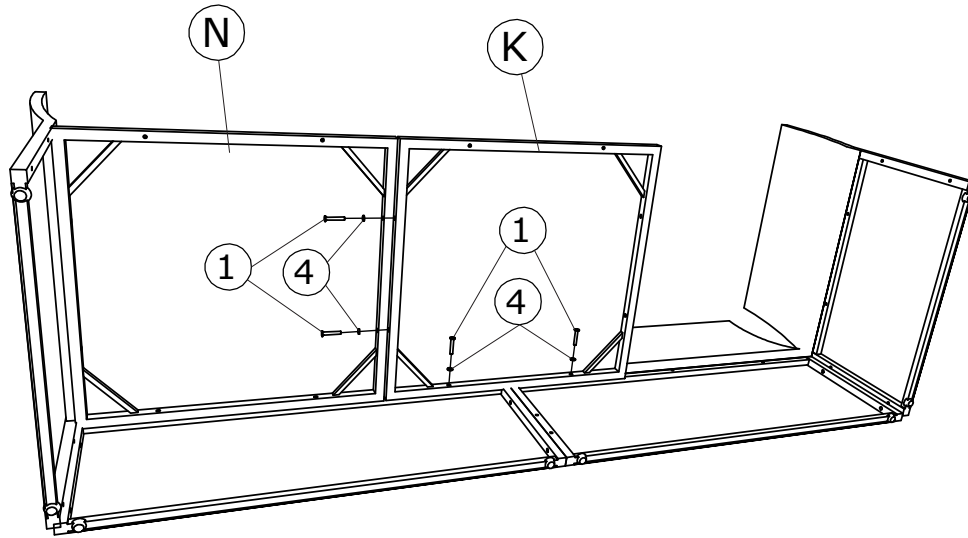

Step 5 :

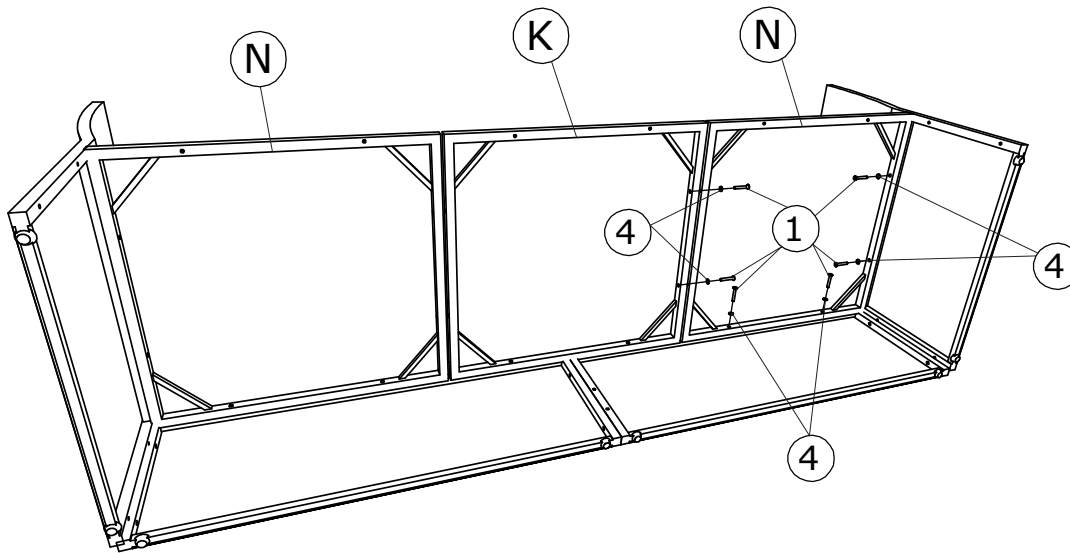

Step 6 :

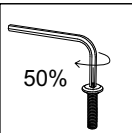
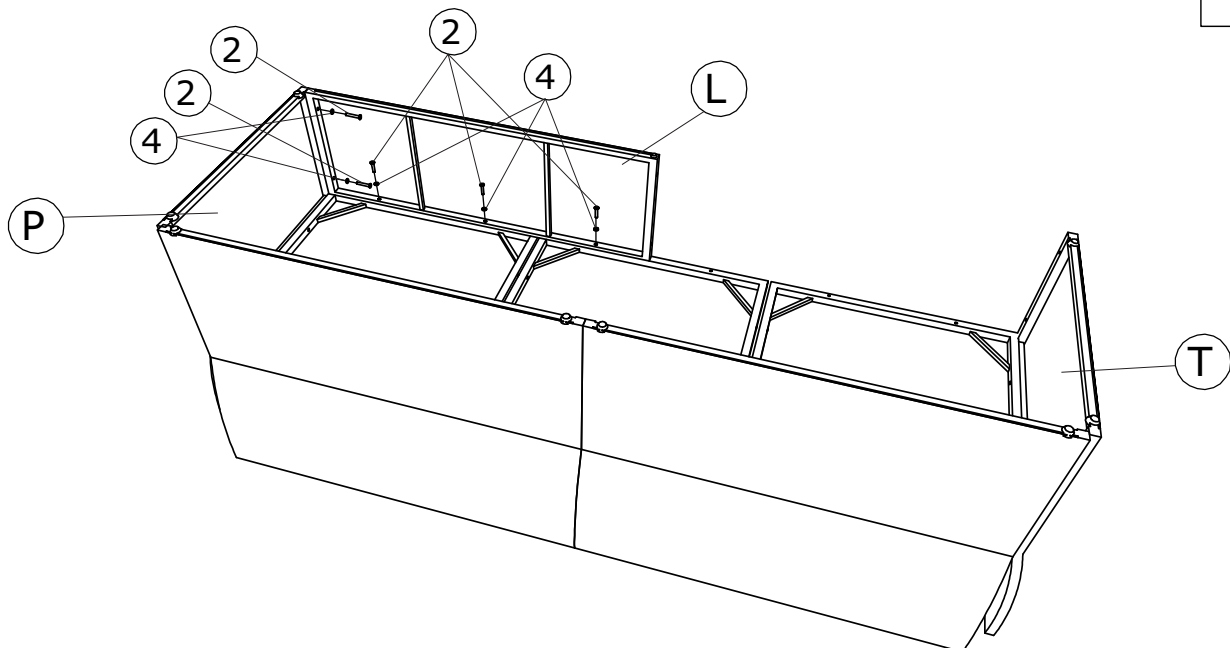

Step 7:

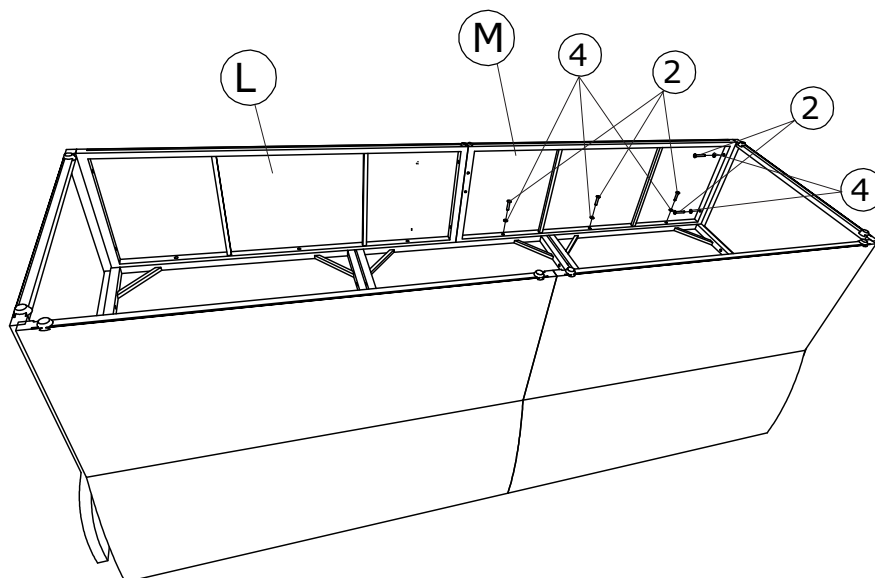

Step 8 :

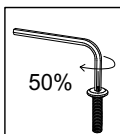
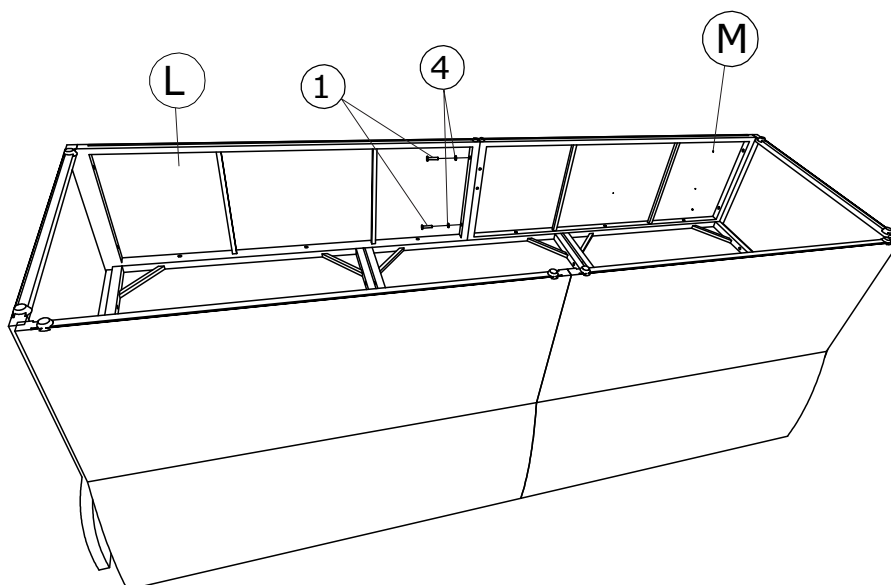

Step 9 :

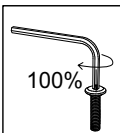
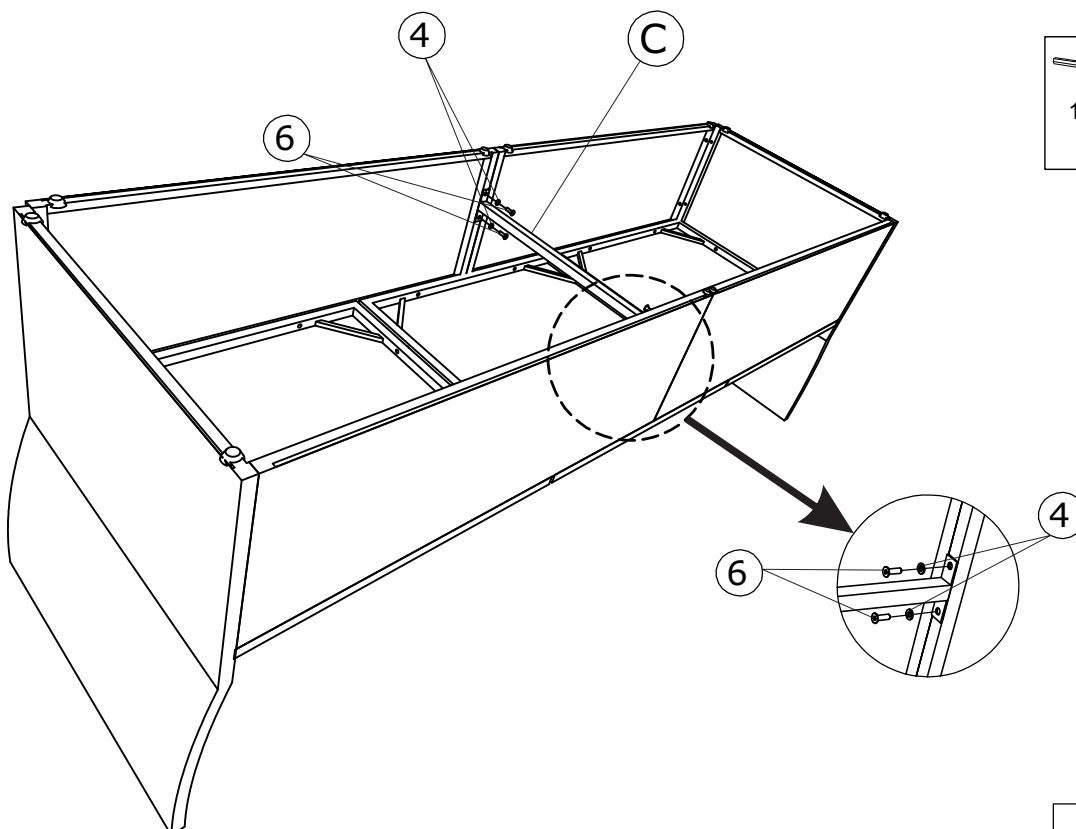

Step 10:

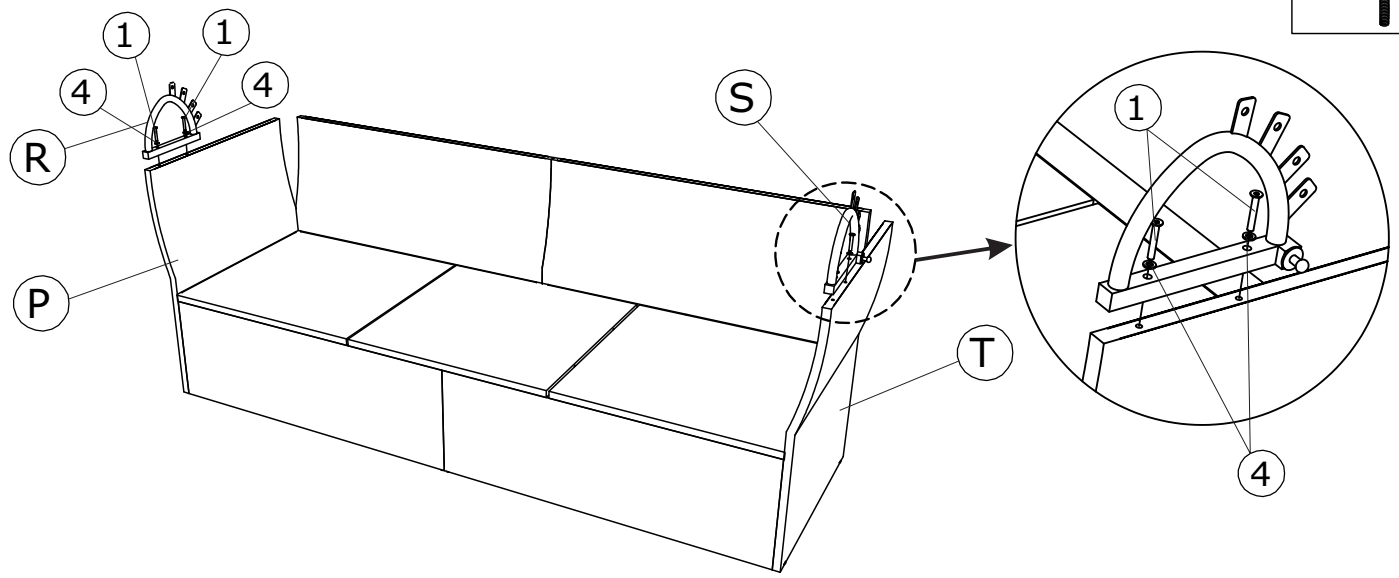

Step 11 : **Part A**

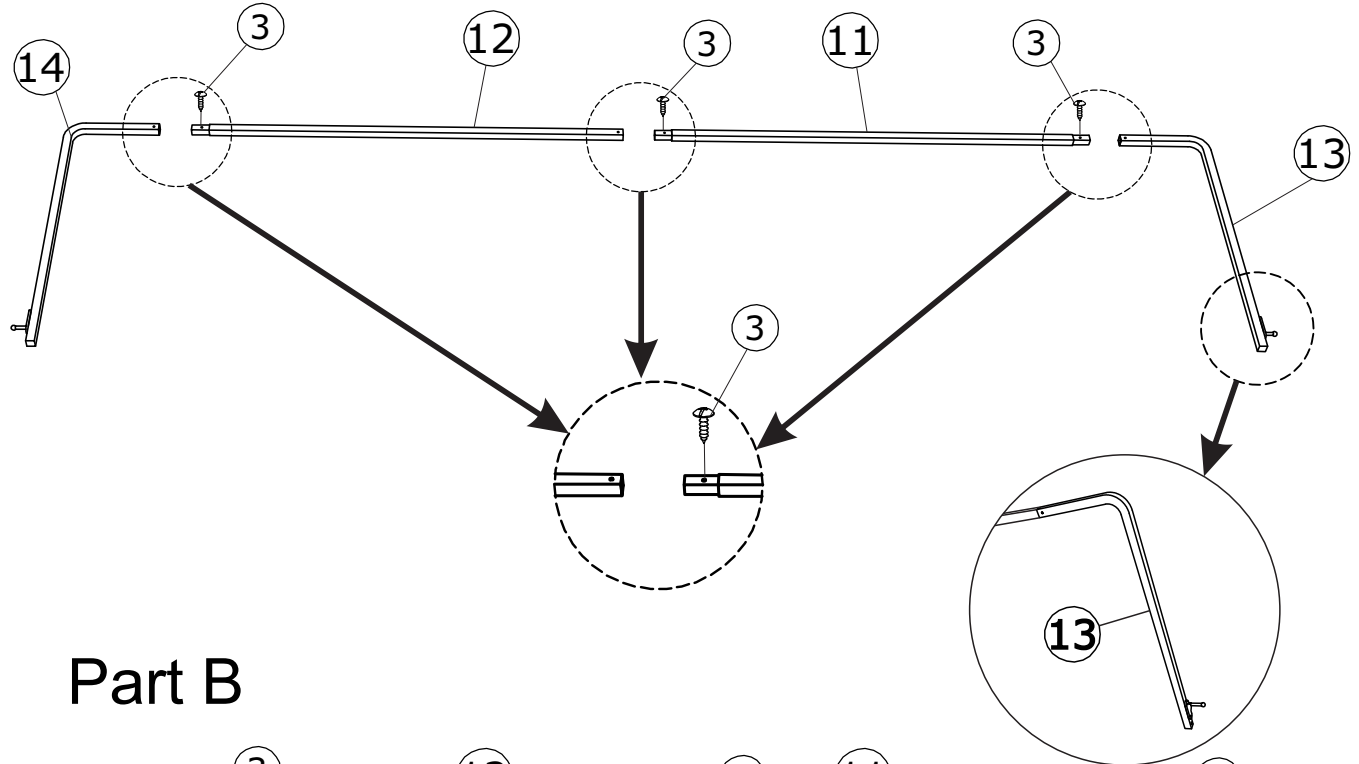

Part B

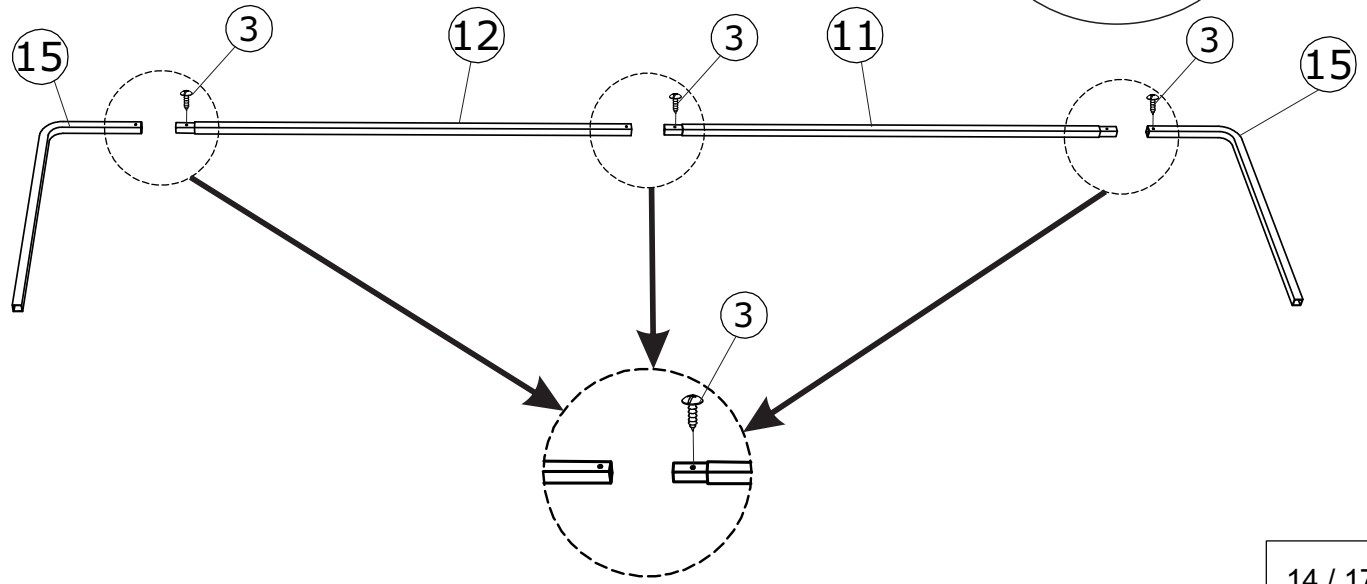

Part C

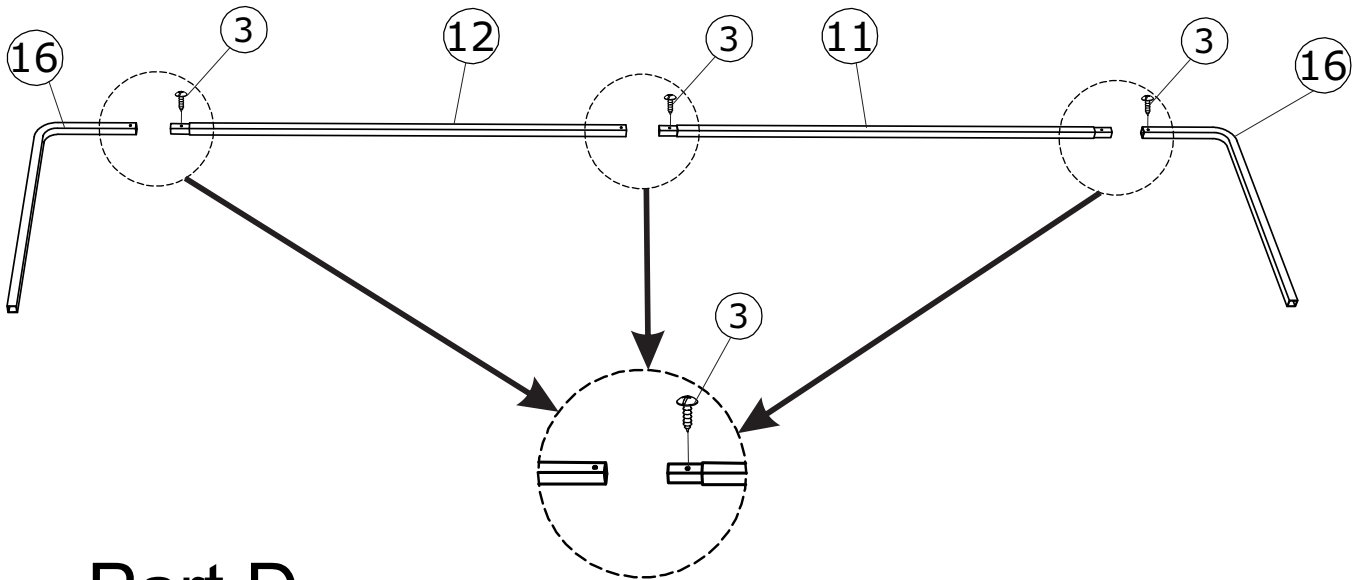

Part D

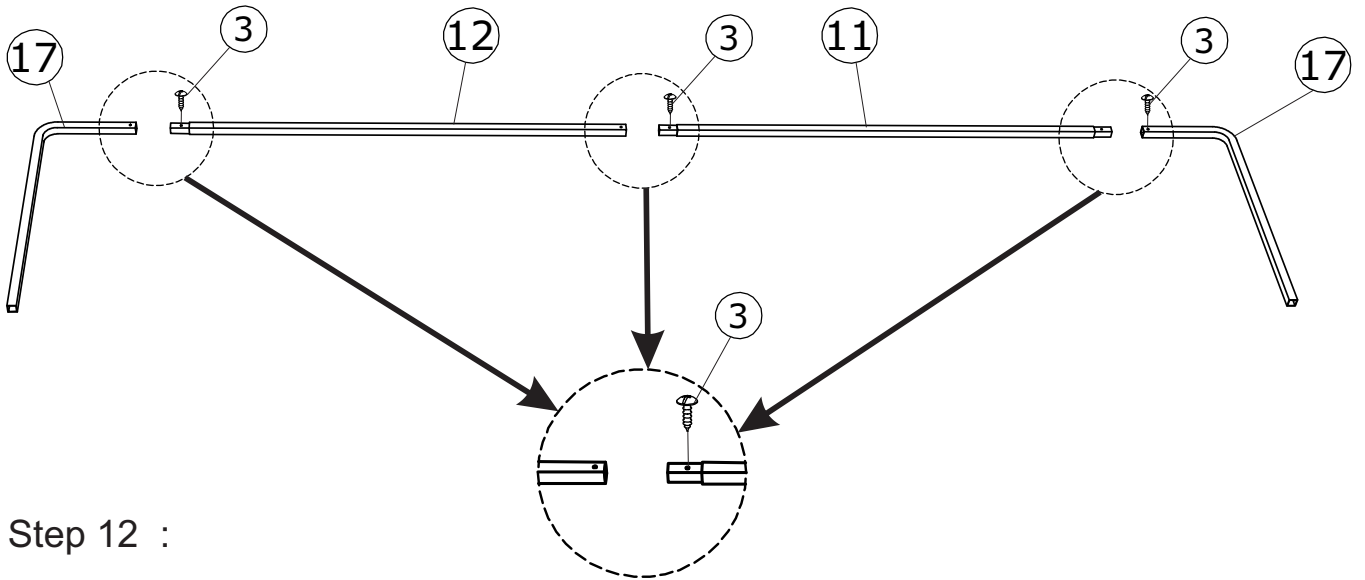

Step 12 :

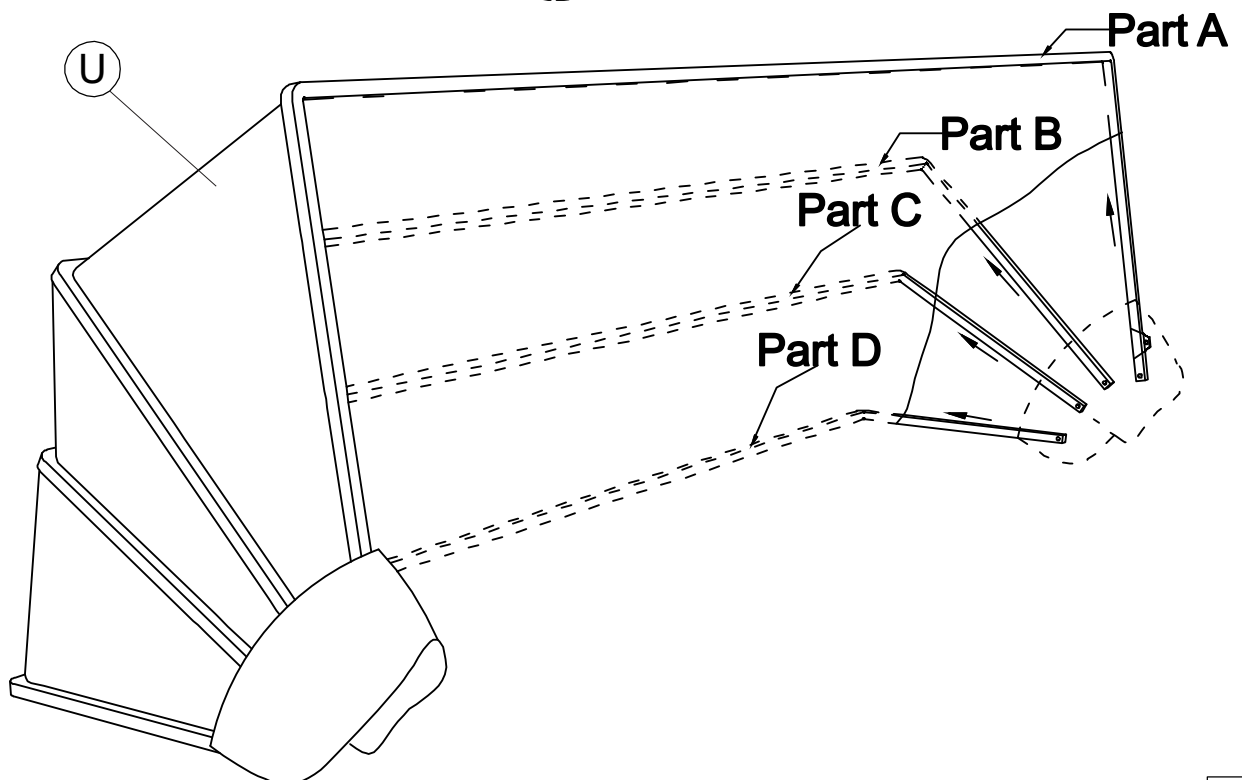

Step 13:

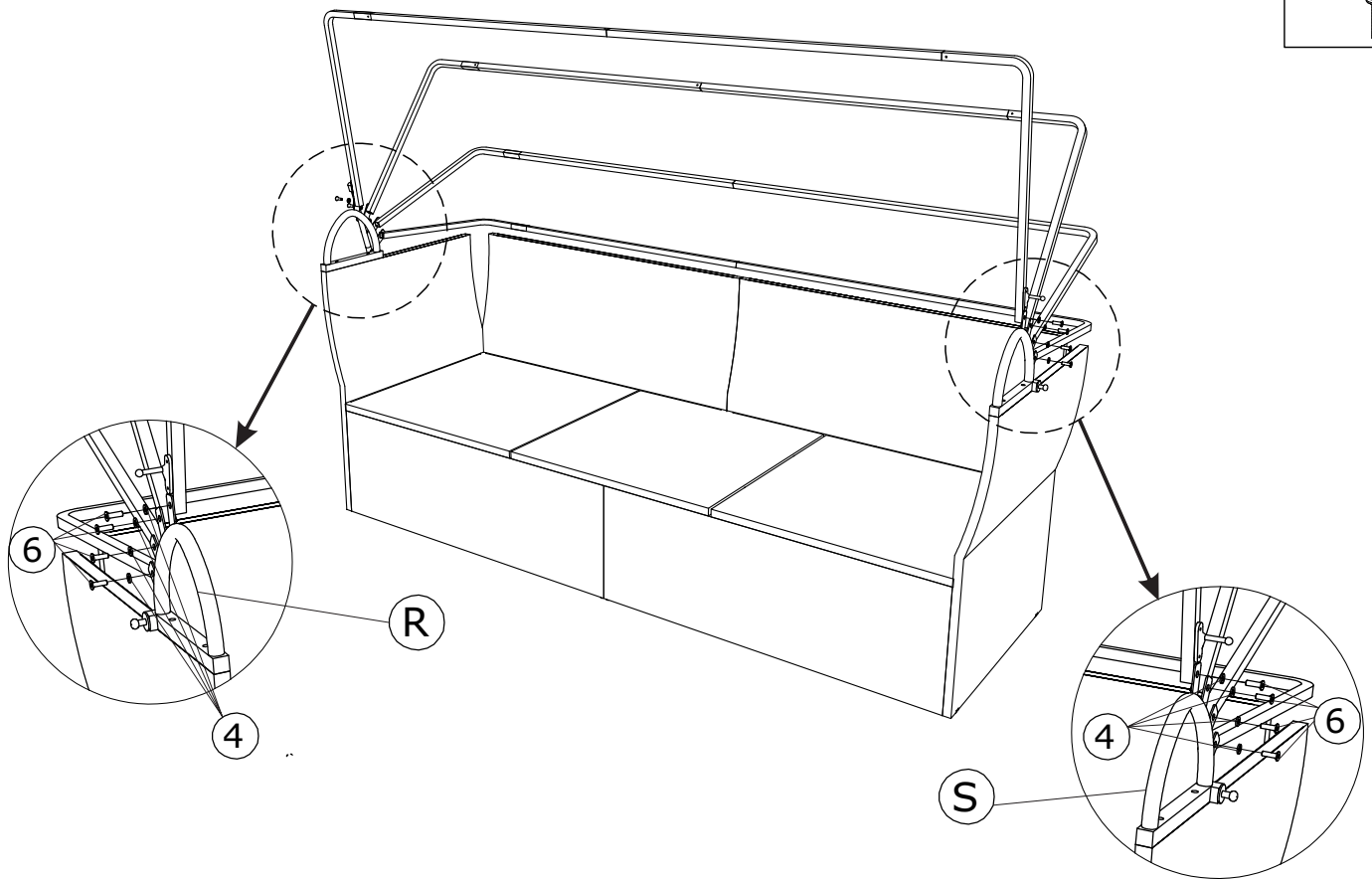

Step 14:

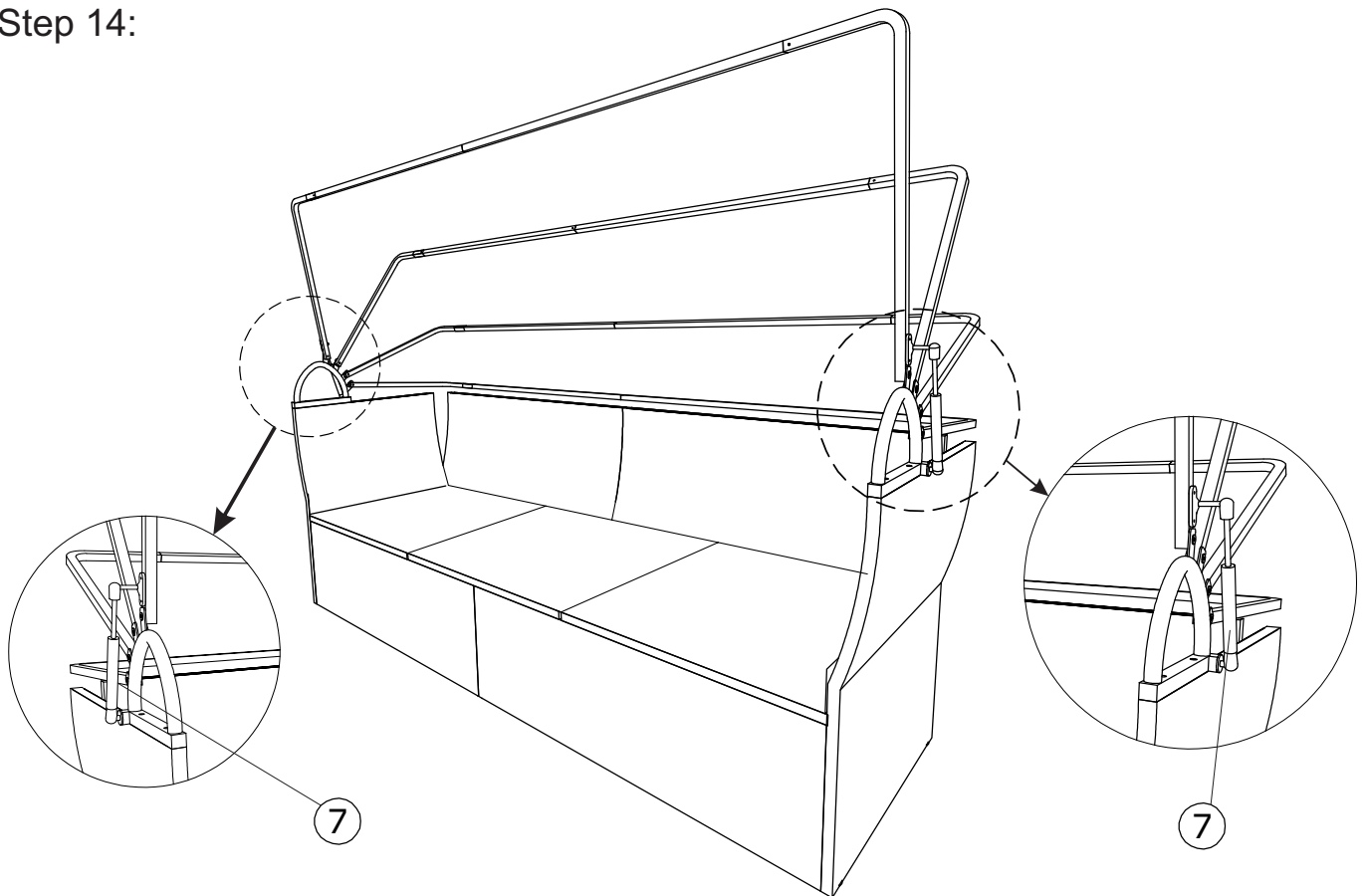

Step 14: CLOSING DOWN

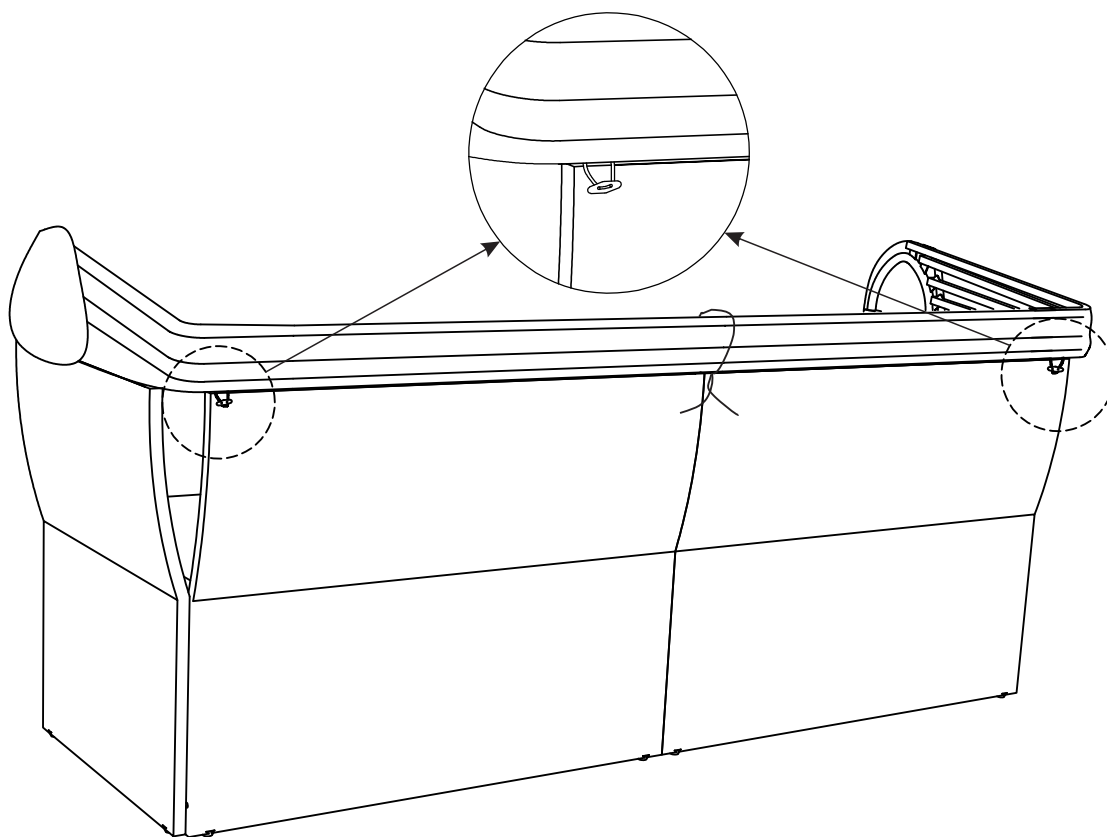

Step 15: OPENING UP

